



Retailer Handbook

Enclosed Properties & Open Air Centers

Dec 2022

TABLE OF CONTENTS

Section One	
Introduction	3
Section Two	
Landlord and Retailer Responsibilities	
Landlord's Work	4
Retailer's Work	4
Section Three	
Retailer Submission and Drawing Requirements	
Submissions-General	9
Submission-Store Working Drawings	9
Sign Submissions	10
Final Approval	10
Code Requirements	10
Section Four Design	
Criteria	
Basic Issue Affecting Retailer's Work	11
Visual Design Criteria-Storefront	11
Visual Design Criteria-Interior Space	13
Store Interior Visual Merchandising	16
Section Five	
Food User Criteria	
Design Standards	17
General information	18
MEP Requirements	18
Counter-Type Operations	20
Food Court Sign Criteria	20
Section Six	
Mechanical/Electrical Design Criteria	
HVAC	21
Fire Extinguishers	23
Plumbing and Gas Piping	23
MEP Penetrations/Roofing/Structure	23
Electric	24
Fire Sprinkler System	25
Smoke Evacuation System	25
Section Seven	
Signage Guidelines	
General	26
Construction Requirements	28
Major Retailer Signage	29
Landlord Signage	29
Minimum Submissions	30
Sign Installation	30
Section Eight	
Closeout Requirements	31
Section Nine	
Contact Information	See Handbook Supplement
Section Ten	
Temporary Graphics Samples	32
Signage Samples	32

Section One Introduction

This Retailer Handbook has been prepared as a guide to assist the Retailer, Retailer's store planner, architect, engineers, and contractors through the process of designing, obtaining approval for, constructing and opening Retailer's store. The information contained in this Retailer Handbook will assist Retailer and its store planner in developing a design that meets Landlord's criteria and will serve as a tool for both Retailer's architect and contractors by providing as much information as possible to assist in expediting their tasks. It is the Retailer's responsibility to provide a copy of this Retailer Handbook to the parties involved with the design and construction of the Retailer's space.

This Retailer Handbook has been broken down into sections as identified in the table of contents so that the Retailer, Retailer's Consultants and Retailer's Contractors can easily navigate and identify specific topics they are looking for regarding the Property.

The Property has a specific **Construction Rules and Regulations Packet that** is to be used in conjunction with the Retailer Handbook to answer most construction questions that come up during the Retailer construction process. The Construction Rules and Regulations Packet contains specific information applicable to the Retailer's Contractor performing work in the Property. The Retailer's Construction Representative or Retailer's General Contractor should contact the Property Operations Director to obtain the Construction Rules and Regulations Packet (CRRP).

Retailer shall schedule and sequence all drawing and construction activity to allow the Premises to be open for business as required in the lease. Failure to meet these required timelines do not alter or waive Retailer's obligations or rent commencement set forth in the lease.

Section Two Landlord and Retailer Responsibilities

Landlord's Work

1. Refer to Exhibit B of the executed lease for Landlord's scope of work, if any.

Retailer's Work

Retailer shall, at its sole cost and expense, perform all work, other than that to be performed by Landlord as set forth in Exhibit B of the executed lease, required to complete Retailer's leased premises to a finished condition ready for Retailer's conduct of business as described below:

1. General
 - A. Retailer shall obtain all permits and approvals, at Retailer's expense.
 - B. Retailer shall obtain property specific Construction Rules and Regulations to distribute to Retailer's Architect and General Contractor.
 - C. Retailer and Retailer's general contractor must contact and schedule a pre-construction meeting with property Operations Director five (5) days prior to work starting.
 - D. Retailer shall have transferred all applicable utilities into Retailer's name prior to construction start.
 - E. Retailer's Work shall be performed in a first-class, workmanlike manner and shall be in good and usable condition at the date of completion thereof.
 - F. Retailer must provide proof of insurance as described in The Lease prior to commencement of ANY work in the Premises by the Retailer, Retailer's Contractor(s) and/or Retailer's Affiliates.
 - G. Retailer's Contractor(s) must provide proof of insurance as described in the Construction Rules and Regulations Packet prior to commencement of ANY work in the Premises by the Retailer, Retailer's Contractor(s) and/or Retailer's Affiliates.
 - H. Retailer and Retailer's General Contractor shall submit weekly construction progress reports and updated schedules, including photos of project progress
 - I. Should the construction involve both union and non-union contractors, Landlord's contractor has included in its contract with all subcontractors, the Harmony Clause set forth below. Retailer shall require such provision to be included in all contracts with Retailer's general contractor and Retailer's subcontractor's as well as requiring Retailer's general contractor to include such provision in their contract with subcontractors so that there shall be no interruption in the process of work. Harmony Clause:

"It is understood that contracts will be awarded by the contractor and labor will be employed on the Project without discrimination as to whether employees, agents, suppliers and/or subcontractors of the contractor or any other subcontractor, including those that may be employed by the Owner of the Project, are members or non-members of any labor or collective bargaining organization, and the subcontractor accepts this contract with this understanding.

"There shall be no manifestations on the Project of any dispute between any labor organization and the subcontractors. The contractor and subcontractor agree to employ personnel, agents, suppliers and subcontractors who will perform the work under their subcontract,

whether or not other employees or mechanics on the Project are members or non-members of any labor or collective bargaining organization.

"The contractor and subcontractor agree not to participate in or permit any cessation of work which may occur as a result of any labor dispute. Should there be a work stoppage caused by a strike, picketing, boycott, or any cessation of work by employees of the subcontractor, his agents, suppliers and/or subcontractors, which in the sole judgment of the contractor will cause, or is likely to cause, unreasonable delay in the progress of construction, then upon forty-eight (48) hours of written notice, delivered either in hand, by telegram, or registered mail, the contractor shall have the right to declare the subcontractor in default of this subcontract, and upon such notice, the contractor shall have the right to take such steps as are necessary to finish the uncompleted portion of the work to be performed by the subcontractor. In such event, the contractor shall have the right to take possession of and use all of the subcontractor's materials (exclusive of tools), intended for the use on the subcontractor's remaining interest in the subcontracted price. If the cost of completion exceeds the subcontractor's remaining interest in the contract price, then the subcontractor agrees to pay the contractor such excess within thirty (30) days after presentation of documented written demand for such excess has been made upon the subcontractor by the contractor."

- J. Retailer's Work shall be subject to the inspection and approval of Landlord's representative and Landlord's architect. Landlord shall have the right to stop Retailer's Work whenever necessary to obtain compliance with applicable building and safety codes or the approved Working Drawings and Specifications. Any of Retailer's Work which does not comply with Retailer's approved Store Working Drawings and Specifications shall be corrected within seven (7) days of notification to Retailer.
- K. Upon the completion of Retailer's Work, all facilities shall be in full use without defects.
- L. Landlord shall have the right to order Retailer or Retailer's contractors who willfully violate any of the within requirements to cease work, and to remove their equipment and employees from the Regional Development.
- M. Charges for all work performed and services rendered by Landlord for or on behalf of Retailer shall be due and payable by Retailer within thirty (30) days after invoicing by Landlord.
- N. Landlord shall have the right, upon written notice, to locate, both vertically and horizontally, utility lines, air ducts, flues, refrigerant lines, drains, sprinkler mains and valves and such other facilities, including access panels for same, within Retailer's leased premises as deemed necessary by engineering design and/or code requirements for Retailer's space or as required for other Retailers.
- O. Landlord shall have the right to locate mechanical and other equipment on the roof over Retailer's leased premises.
- P. Landlord shall have the right to order Retailer or Retailer's contractor who willfully violate any of the above requirements to cease work and to remove itself and its equipment and employees from the Property.

2. Temporary Barricades

- A. Temporary storefront construction barricades are required during construction. Retailer is responsible for installation and removal temporary barricades, if not already pre-existing. Retailer's temporary barricade plan to be approved by Landlord or Landlord's

- corporate project manager prior to Retailer proceeding with construction of the temporary barricade and must be installed within five (5) days after lease execution. Retailer is responsible for all patching and repairs caused from the removal of the temporary barricade by the Retailer.
- B. If the Landlord determines a temporary barricade is not required, the Retailer is responsible for blacking out all storefront windows within five (5) days after lease execution and prior to construction start and shall remain until Retailer is fully stocked and ready to open.
 - C. Retailer is also responsible for installing promotional "Coming Soon" graphics on the temporary barricade or windows, whichever applies. All graphics must be submitted to Landlord or Landlord's corporate project manager for review and approval and installed within five (5) days after the later of lease execution or barricade construction.
3. Clean-Up and Demolition
- A. Retailer and Retailer's contractors shall be responsible for the complete and total demolition, if applicable, of any and all existing materials which are not to be reused including, but not limited to, studs, drywall, ceilings, ducts, conduit, plumbing, floor finishes, soffits, etc.
 - B. Landlord shall inspect and be required to sign off on Retailer's demolition at Retailer's expense. Under no circumstances shall any portion of Landlord's building structure to be demolished without Landlord's written approval and a Landlord representative present including, but not limited to, columns, slabs, grade beams, demising walls, utilities and bulkhead assemblies.
 - C. Retailer shall provide an area for dry rubbish collection containers within Retailer's leased premises.
 - D. Should Retailer generate wet garbage, wet garbage containers shall be provided by the Retailer.
 - E. Retailer and Retailer's contractor shall be responsible during construction and fixturing for Retailer's trash removal. Do not use the property's trash containers and equipment, unless directed to by the property Operations Director.
 - F. Retailer shall provide dumpsters placed in a location designated by the Property management.
 - G. Should Retailer or Retailer's contractor be negligent and fail to remove trash on a timely basis (no accumulation is allowed), Landlord, at its option, may remove same and Retailer agrees to reimburse Landlord.
4. Temporary Utilities and Service:
- A. **Retailer is responsible for obtaining and paying for temporary electric and water for Retailer's use during construction including reimbursing Landlord for services in wpg's name.**
 - B. Retailer is responsible for transferring all existing utility services into their name at Delivery of the Premises to Retailer and prior to commencing any Retailer work in the Premises.
5. Retailer Construction Guidelines:
- A. A list of required contractors that must be used for the Property is located in the Rules and Regulations for the center. Retailer/General Contractor to contact the Property's General Manager/Operations Manager to retain a copy of the Rules and Regulations.

- B. The Retailer's contractors shall coordinate all aspects of Retailer's Work with the Property Operations Director.
 - C. Fire sprinkler lines shall remain active during construction. Landlord's insurance carrier requires the fire sprinkler system in construction areas to be live at all times except during actual alterations of the lines and/or sprinkler heads.
 - D. The fire sprinkler system shall only be inactive during the actual changing of the lines and heads which will be under the direct supervision of Property management.
 - E. The Property fire sprinkler system is set up in "zones" meaning any shut down will impair the system in several areas. Therefore, if the system cannot be reactivated by 9:00 PM, Retailer's contractor will be billed for extra security to monitor and perform "fire watch" throughout the building until the fire sprinkler system is active. The Retailer will be billed by the Property to refill the sprinkler system.
 - F. Retailer shall provide a fire alarm system, at Retailer's expense, in accordance with local governing jurisdictions.
 - G. In all areas where Retailer has set the storefront back from the lease line, Retailer shall install base building floor tile from the lease line to the recessed storefront. Retailer's floor must be flush with the Property common area floor.
 - H. In certain circumstances, Landlord may provide materials and/or construction of items at Retailer's cost.
 - I. Surfaces or projections potentially hazardous to Property pedestrian traffic may not be used.
 - J. Retailer shall provide sprinklers for its storefront area, at Retailer's expense, in accordance with the requirements of the prevailing codes. Sprinklers within this area shall be either semi-recessed or fully recessed.
 - K. Depressed floor slabs are not be permitted.
 - L. Any penetrations planned by Retailer through the roof or the floor of the leased premises must be approved by Landlord at the time of plan preparation. This work may require X-ray surveying. Retailer shall coordinate this work with the Operations Director.
 - M. Fastening to or suspension from the underside of the floor or roof structure is not permitted without Landlord's prior written approval. Unistrut, or equal, support system is required for all suspended items.
 - N. Large items (transformers, HVAC, water heaters) that the Retailer proposes to hang from the deck above, must be approved by the Landlord, and be detailed by a structural engineer. The cost of the structural design shall be by the Retailer.
 - O. Wall-mounted fixtures will not be permitted without Landlord's prior written approval.
 - P. Mezzanine floors are not allowed unless specifically approved, in writing, by Landlord.
6. Working Hours: Refer to the **Construction Rules & Regulations Packet** for information regarding working hours in the Property.
 7. Delivery Policy: Refer to the **Construction Rules & Regulations Packet** for information regarding Deliveries in the Property.
 8. Quality Standards:
 - A. Retailer shall require any person performing work to guarantee the work to be free from any and all defects in workmanship and materials for one (1) year from the date of completion thereof. Retailer shall also require any person to be responsible for the replacement or repair without additional charge of any and all work done or furnished by or through such person who shall become defective within one (1) year after substantial completion of the work. The correction of such work shall include, without additional charge, all expenses and damages in connection with the removal, replacement or repair

- of any part of the work which may be damaged or disturbed thereby.
- B. All warranties or guarantees to materials or workmanship on or with respect to Retailer's Work shall be contained in the contract or subcontract which shall be so written that such warranties or guarantees shall insure to the benefit of both Retailer and Landlord, as their respective interest may appear, and can be directly enforced by either. Retailer shall covenant to give Landlord any assignment or other assurances necessary to affect the same.
9. Coordination:
- A. Retailer's Work shall be coordinated with the work being done by Landlord and other Retailers in the Property so that Retailer's Work will not interfere with or delay the completion of any other construction work in the Property.

Section Three

Retailer Submission and Drawing Requirements

Retailer improvements are subject to Landlord's approval and shall conform to all design criteria. Retailer should discuss specific thoughts about its design concept and raise any questions about the documents with Landlord before beginning preliminary design work. Any deviations from the criteria shall be at the sole discretion of Landlord.

Retailer's plans for design and completion of improvements to the Premises shall be prepared by an architect or registered engineer licensed in the State in which the Shopping Center is located or other applicable governmental authority, inclusive of the Americans With Disabilities Act (ADA). Within ten (10) days of execution of the Lease, Retailer shall notify Landlord of the name, address and contact person of its architect or registered engineer, and construction representative.

It is imperative that all requirements outlined in this Retailer Handbook be strictly adhered to by Retailer and Retailer's architect. Failure to do so will only result in unnecessary and costly delays in the approval of Retailer's plans.

Submissions-General

Prior to commencing construction, Retailer shall provide complete working drawings and specifications for the construction of its leased premises within twenty-one (21) days of lease execution in order to receive Landlord's written approval. **LANDLORD MUST GRANT WRITTEN APPROVAL OF RETAILER'S CONSTRUCTION DOCUMENTS BEFORE RETAILER MAY SUBMIT FOR NECESSARY BUILDING PERMITS.** Retailer shall provide one (1) hard copy set of black line prints or (1) PDF. All email submissions shall be made to constructions submit@washingtonprime.com. All drawings and specifications must be clearly identified with the Property name, Retailer's store name and Retailer's space number.

Note that Retailer may submit Preliminary Drawings to Landlord for review prior to submission of Retailer's Working Drawing Submission. The purpose of the preliminary design phase is to acquaint Landlord with Retailer's intentions so Landlord may comment and/or advise Retailer of necessary changes to meet established criteria before Retailer proceeds with its final working drawings and specifications. ***This submission may be done at the discretion of the Retailer but is not mandated by the Landlord.***

Submission - Store Working Drawings

The working drawings shall include the following:

1. Key Plan showing the location of the demised premises;
2. Floor Plans showing all partitions, doors, materials, finishes, store fixtures, plumbing fixtures and other construction on a ¼"-1' scale;
3. Overall Sections showing materials and finishes on a 1/8"-1' scale;
4. Reflected Ceiling Plan showing materials, finishes, lighting plan, description of fixtures, locations of electrical and telephone panels and ceiling heights on a ¼"-1' scale;
5. Location and quantity of all items required to penetrate the Roof or Parking Deck.
6. Plan, Section and Elevation, including signage and graphics, of storefront at ½ "-1' scale;
7. A one (1) point Perspective Color Rendering of the proposed storefront including graphics and signage;
8. Photographs of Retailer's existing storefront, if any, and if related to Retailer's submission;
9. Finish and Color Schedule

10. Samples of storefront materials and colors, including examples of carpet, if any, and appropriate specifications, mounted on foam core or card stock, clearly labeled and referenced on the attached Room Finish Schedule, if the Landlord project manager requests it.
11. Interior Elevations on a ¼"-1' scale;
12. Details of special conditions, including mezzanines, showing the location and weights of heavy equipment such as safes, equipment cases, refrigeration equipment and any masonry facing materials on a ½"-1' scale;
13. Details of the storefront on a ½"-1' scale;
14. Door Schedule with jamb details;
15. Structural Plans, if applicable, prepared by a licensed engineer in the State where the Property is located.
16. Mechanical Plan on a 1/8"-1' scale;
17. Fire Sprinkler Plan showing modifications to Landlord's standard grid on a ¼"-1' scale;
18. Electrical Plans showing complete circuitry, prepared by an engineer licensed in the State where the Property is located, on a 1/8"-1' scale;
19. Electrical details, single line diagram, and fixture and panel schedules
20. Fire Alarm plan and details.
21. Single Line Plumbing Riser Diagram.

Failure to provide adequate information at any phase will be cause for return of Retailer's submission with no review. The submission at the design phase must be complete in order to fairly evaluate the proposal and prevent continuation of work on an unacceptable storefront design. Submittals shall be forwarded to the Project Manager as specified in Section Two - Contact Information.

Sign Submissions

Signage Plans shall be submitted separately in accordance with Retailer's Lease Agreement Signage Exhibit and as expanded upon by the design and technical requirements contained in this Retailer Handbook.

Final Approval

Landlord, upon approval of the demised premises, shall forward to Retailer and/or Retailer's Consultant one (1) set of Retailer's plans bearing Landlord's approval. Retailer shall provide Retailer's contractor and mall Operations Director with a copy of the approved plans and specifications and shall have the approved plans and specifications at the job site at all times. Retailer's contractor may not commence with Retailer's Work until said approved plans and specifications are physically within the demised premises and a building permit has been obtained.

Retailer and/or Retailer's contractor may not deviate from the approved plans and specifications. Any deviation shall be resubmitted for Landlord's approval.

Code Requirements

Retailer shall ensure compliance with all relevant codes, obtain all approvals and pay all fees in connection therewith. Landlord's approval of Retailer's plans and specifications does not signify compliance with code.

Section Four

Design Criteria

Basic Issues Affecting Retailer's Work

1. Stockroom Layout/Exiting
 - A. The exit pathway through Retailer's stockroom must be kept absolutely free of trash, merchandise, shelving, furniture, etc. at all times.
2. Structural Limitations
 - A. Demising walls are non-load bearing. Fixtures shall not be supported from Landlord's demising partitions.
 - B. Demising walls must be finished with five-eighths inch (5/8") fire coded and fire taped from the floor slab to the underside of the roof deck within Retailer's leased premises gypsum board. Existing walls must be corrected to meet this requirement.
 - C. Overhead structural loading shall be done only with Landlord's permission. All structural design costs and any applicable review costs of Landlord's engineer shall be Retailer's responsibility.
 - D. No structural alterations, additions or reinforcements shall be made to Landlord's structure without written approval from the Landlord. Landlord may elect to have Landlord contractor perform any structural modifications at Retailer's expense.
3. Materials Limitations
 - A. Documentation of Retailer's material classifications must be available onsite.
 - B. All project related finishes shall be commercial grade.
 - C. Non-combustible lumber shall be used. Exceptions pertaining to wood trim shall be as determined by code officials.
 - D. Retailer's carpet and wall finishes shall be Class I finish only
 - E. Any finishes or materials to be reused must be approved by Landlord's Corporate Project Manager. These approved items at minimum shall be refurbished to like new condition
4. Thresholds shall be five-sixteenths of an inch (5/16") or per ADA requirements, whichever is more stringent
5. Fire Protection Sprinkler System
 - A. Retailer shall be responsible for the installation of, or modifications to, an approved, code-compliant sprinkler system.
 - B. Retailer shall submit stamped sprinkler drawings to Landlord and Property Management Team prior to construction.

Visual Design Criteria-Storefront

1. General Information
 - A. Retailer shall submit colored renderings of storefront to Landlord's Corporate Project Manager for review and approval.
 - B. Retailer's storefront shall be established six inches (6") back from the face of the neutral pier.

- C. Landlord will require glass, signage, display windows or other translucent materials in solid portions of Retailer's storefront.
- D. Retailer shall not be permitted to install any opaque section of storefront over a length of six feet (6') unless specific approval is granted by the Landlord. Painted gypsum board is not an acceptable storefront and will not be permitted in Retailer's storefront design.
- E. Should Retailer's storefront be located within a curved or radial lease line area, it must be kept four inches (4") back of Retailer's lease line.
- F. Construction that flattens or otherwise alters Retailer's curved or radial lease line is not permitted.
- G. Recessed out-swinging doors shall not extend past Retailer's lease line when fully open.
- H. Doors may be fully glazed, solid or any combination thereof.
- I. Refer to Storefront Signage Criteria at end of Section Five - Design Criteria for additional design restrictions and guidelines.

2. Storefront Finish Treatments

A. As a guideline, acceptable treatments include:

- Limestone, marble, granite and other natural stone products carefully articulated and detailed;
- Lacquered surfaces in a minimum of four (4) coats;
- Metals, excluding laminates; and
- Stained or natural finished hardwoods.

B. The following are unacceptable finishes:

- Mirror;
- Rough sawn wood;
- Painted drywall;
- Wallcovering;
- Undetailed brick;
- Rough stucco; and
- Anything Landlord would consider a non-durable material or lacking in visual quality.

C. Glazing

- I. Simulated, applied or reproduced glass in acrylic or Plexiglas is not permitted.
- II. The use of attractive and high-quality clips or brackets that complement the design of store is required.

3. Visual Merchandising

- A. Retailer shall provide sufficient architectural space, lighting, transparency and framing to allow and enhance professional visual merchandising.
- B. The Design Control Area, which consists of the window display and storefront is to emphasize attractive and compelling presentation of Retailer's merchandise and creative visual merchandising techniques and props.

C. The Design Control Area is to be set off from Retailer's sales area by contrasting visual techniques through:

- Merchandising;
- Fixturing;
- Display platforms and walls;
- Lighting;
- Special finishes; and
- Special flooring.

D. The following items are prohibited in the Design Control Area:

- Slat wall of any type;
- Full height or full width backwalls;
- Boxed merchandise; and
- Exposed concrete floor unless stained and sealed.

4. Entrance Doors

- A. The use of hinged doors is encouraged.
- B. Overhead rolling grilles are acceptable and are approved on a case by case basis.
- C. Retailer electronic article surveillance (EAS) system must be concealed. Design of system must be approved by Landlord prior to construction.

Visual Design Criteria-Interior Space

1. Floor Treatments

A. A hard surface floor material is required at Retailer's storefront lease line. The following floor finishes may be used:

- Marble, granite or stone;
- High quality, commercial grade carpet;
- Hardwood flooring;
- Terrazzo; and
- Ceramic tile which is mosaic, twelve inches by twelve inches (12" x 12") or larger.

B. The following floor treatments are not permitted:

- Ceramic tile which is residential size unless done in a patterned design;
- Astroturf;
- Residential grade carpeting;
- Bare unfinished concrete;
- Vinyl sheet goods; and
- VCT in Retailer's sales area.

- C. Carpet Treatments
 - I. Carpeting must be of a superior quality.
 - II. Direct-glue carpet installation is preferable to carpets installed over padding for greater durability and wear.
 - III. Transitions between finishes must minimize unsightly distractions and walking hazards.
 - IV. Floor treatment reducer strips can be trip hazards and are not permitted.

2. Wall Treatments
 - A. The following are acceptable wall finishes:
 - wood trim, moldings and panel treatments;
 - cast architectural elements;
 - painted gypsum board;
 - pre-finished or perforated metal panel;
 - back-painted, back-lit or etched glass;
 - special paint finishes;
 - marble, granite, limestone or other natural stone finish; and
 - commercial grade fabric wall coverings, synthetics and vinyl materials.

3. Columns
 - A. Exposed columns may be retained but must be painted, treated at the base and capitol (top) to conceal existing connections, and fit conceptually within Retailer's overall scheme.

4. Mirrors
 - A. Mirrors in dressing rooms are encouraged.
 - B. Mirrored wall treatments, particularly as backgrounds to merchandise, are discouraged.
 - C. Mirrors shall not be used in Retailer's storefront design.

5. Ceiling Treatments
 - A. For approval of Retailer's working drawings and specifications, all components in Retailer's ceiling must be shown.
 - B. A gypsum board ceiling is encouraged.
 - C. Lay-in ceilings, in combination with gypsum board ceiling drops, are encouraged.
 - D. Junctions between differing ceilings types are best articulated by a vertical distance of at least four inches (4") as measured between their horizontal planes.
 - E. Lay-in ceiling tiles in sales area shall have profiled edges. Square edge tiles not permitted
 - F. Open ceilings to structure above may be permitted if granted written approval by the Landlord.
 - G. Access panels are required in hard lid ceilings as part of the ceiling design to access utilities and other mechanical components

6. Dressing Rooms
 - A. Dressing rooms must comply with the Americans with Disabilities Act.

7. Cash Wrap

- A. Retailer's cash wrap must incorporate built-in hanger and refuse areas.
- B. Retailer's cash wrap must comply with Americans with Disabilities Act requirements regarding access, facilities and counter heights.
- C. Countertops shall be solid surface, no plastic laminate.

8. Interior Signage and Graphics

- A. Permanent interior signage and graphics should be three (3) dimensional, of a substantial material, and must be submitted with Retailer's signage package for approval by Landlord.
- B. Promotional and sale signage should be sent to Property Management team for review and approval prior to installation.

9. Video

- A. The use of electronic graphics requires Landlord's approval.
- B. Television monitors, slide format and other devices must be shrouded, framed or encapsulated so only the image is seen and shall be set back from the storefront. Contact the wpg Project manager for site specific setback distance.

10. Sound

- A. Sound systems should be professional installed with built-in speakers and concealed components, which are accessible by Retailer's store manager only.
- B. When choosing speakers and components that are visible, Retailer should be sure they agree with other store design elements.
- C. Sound migration affecting the Property concourse and neighboring Retailers is prohibited.
- D. If required by the local governing jurisdiction, sound systems must be tied into the fire alarm system to automatically shut off during alarms.

11. Drinking Fountains

- A. Water fountains must not be visible from the Property concourse.

12. Lighting

A. Ambient Lighting

- I. Lighting sources to be considered for ambient lighting include:
 - Recessed LED, halogen par lamps, or incandescent down lights;
 - Fluorescent or neon cove lighting with the lamp or tube not visible;
 - Recessed metal halide light fixtures;
 - Custom designed chandeliers or suspended light fixtures; and
 - Lay-in fluorescent light fixtures with deep cell parabolic lenses.
- II. The following light sources are not permitted:
 - Acrylic sheet or shallow cell lenses;
 - High- or low-pressure sodium;
 - Mercury vapor; and
 - Cool white fluorescent.

- Any flashing or blinking apparatus

B. Focal/Perimeter Lighting

- I. Retailer shall illuminate merchandise displayed on wall fixtures.
- II. Retailer should consider the following lighting sources for focal/perimeter lighting:
 - Suspended light fixtures;
 - Track lighting of a low and/or line voltage system;
 - Recessed compact fluorescent or halogen down lights; and
 - Indirect fluorescent lighting within coves or valances having a high color-rendering index of T-8 lamp color equivalent of 3500° K with lamps not visible from Retailer's sales floor.

C. Exit Signs and Emergency Lights

- I. Retailer is required to use exit signs and emergency lights with remote battery packs.
- II. Exit signs should be edge-lit or recessed models.
- III. Retailer's lighting designer should coordinate Retailer's exit light sign and emergency lighting locations with Retailer's ceiling design to achieve the most desirable and least obtrusive sight lines.

D. Accent Lighting

- I. The following lighting fixtures should be considered for accent lighting:
 - Theatrical spot lighting instruments;
 - Track light fixtures of low and line voltage systems; and
 - Recessed, directionally adjustable fixtures.

E. Task Lighting

- I. The following lighting fixtures should be considered for task lighting:
 - Commercial quality table lamps; and
 - Commercial quality floor lamps.

Store Interior Visual Merchandising

1. Visual merchandising shall be included with Retailer's document submission and shall include the following:
 - A. Retailer is required to create an ambitious and creative visual merchandising program.
 - B. Floor plans indicating the location of focal points and vignettes and wall elevations illustrating the character of the focal points and vignettes;
 - C. Pedestals, risers and showcase interiors, finishes and props;

Section Five

Food User Criteria

FOOD COURT CRITERIA

The following criterion is specific for food Retailers including restaurant, inline food Retailers and those in the food court. This information is in addition to the criterion covering the basic design and technical criteria for all Retailers. This information has been assembled to assist Retailer's architect and its consultants in preparation of Retailer's construction documents and specifications. Retailer's architect is responsible for adhering to the requirements outlined in Retailer's Lease Agreement and the following additional requirements.

Design Standards

1. Restaurants
 - A. The basic criteria for Property Retailers govern; however, restaurant designers should consider the food court as an amenity providing views, vistas and visual excitement.
 - B. Operable windows onto the Property which, create a sense of a sidewalk café are encouraged.
 - C. Inline food and restaurant Retailers are required to use hinged door entries.
 - D. Overhead rolling grilles are not permitted.
 - E. All floor finishes at Retailer's storefront lease line shall be the same finish floor elevation as Landlord's Property floor.
 - F. All wet areas, including but not limited to all kitchens, prep areas and toilet rooms, will be required to have a Landlord approved waterproof membrane installed between the structural slab and Retailer's finished floor that extends up the wall at least 6".
 - G. All waterproofed floors, located above grade level, will be required to be tested and witnessed by the Property Operation Director. Typically, this is a 90-minute flood test.
 - H. Any food user wishing to re-use an existing floor with a waterproof membrane will be required to perform and pass a flood test to be witnessed by the Property.

2. Food Court
 - A. All materials employed in Retailer's storefront shall be made of hard surface, durable materials that require minimum maintenance.
 - B. All storefront work requiring structural support shall be floor-supported and braced at the head sections by a welded structural steel framework secured to the existing building steel structure.
 - C. Storefront grilles, if any, shall be concealed in an overhead or side storage pocket during Property hours.
 - D. Expansion joints in Retailer's storefront must be detailed and illustrated in Retailer's working drawings and specifications, incorporated into Retailer's storefront design and inconspicuous.
 - E. All diffusers, grilles, tracks, etc. must be painted to match Retailer's finished ceiling.
 - F. Retailer shall provide access panels to permit servicing of all equipment located above Retailer's ceiling.
 - G. Access panels in hard ceilings must be flush with the adjacent finishes.
 - H. Access panels should be installed on vertical ceiling soffits or located as inconspicuously as possible.
 - I. Only quarry or ceramic tile are permitted within Retailer's merchandising zone.

- J. Rubbish storage rooms and mop sinks are to be provided in all food court Retailer spaces.
3. Inline Food Retailers
- A. The basic criterion for Property Retailers governs.
 - B. Service counters are not allowed within the Design Control Area.
 - C. Open area and access to the service counter shall be achieved using hinged doors and windows.

General Information

1. Toilet Rooms
- A. All toilet room floors above grade level shall have a waterproof membrane (shown on Retailer's construction drawings) between the structural sub-floor and Retailer's finished floor.
 - B. All toilet rooms shall have ceramic tile sanitary floors and bases that extend a minimum of four inches (4") above Retailer's finished floor.
 - C. Retailer is required to provide floor drains and thresholds.
2. Rubbish
- A. All food or beverage service Retailers shall provide a storage room area for rubbish.

Specific MEP Requirements

1. Grease Traps
- A. All grease trap designs shall be coordinated to existing conditions of the Property. Coordinate design with Landlord Retailer Coordination team and onsite property management personnel.
 - B. If code permits Retailer to provide a grease containment unit internal to their premises, the following guidelines must be followed:
 - I. The grease trap cannot be installed in the food preparation area.
 - II. The grease trap must be accessible for cleaning.
 - III. The maximum size/capacity of the grease trap unit shall be fifty gallons per minute (50 gpm) flow rate or more as may be required by code.
 - IV. Retailer's grease trap unit requires Landlord's approval.
2. Exhaust and Flue
- A. Exhaust Hood Systems
 - I. Retailer shall provide and install all exhaust equipment, ductwork, controls, etc. as required for the complete installation of each kitchen hood as required by all applicable codes or as directed by Landlord's Retailer Coordinator.
 - II. Any and/or all other necessary Retailer roof penetrations are to be made, flashed and sealed, inclusive of protective grease resistant roof membrane, per Landlord's requirements by using Landlord's roofing contractor, at Retailer's expense.
 - III. Retailer shall provide, at Retailer's expense, a grease containment system meeting Landlord's requirements and applicable codes.

- IV. Retailer is responsible to maintain (clean, repair, etc.) the grease containment system at Retailer's expense.
- V. Food court restaurant and inline food Retailers shall be responsible for the design and installation of cooking equipment hood systems in accordance with the requirements of all applicable governing authorities.
- VI. Under no circumstances shall the amount of make-up air introduced through Retailer's equipment be less than ninety percent (90%) of that exhausted by Retailer's hood.
- VII. Retailer's exhaust hoods shall be constructed in accordance with all applicable codes and regulations.
- VIII. Return air shall be introduced with rear drop air plenum.

B. Fire Suppression

- I. Retailer shall provide a factory pre-piped wet chemical type fire suppression system for each hood complete with the appliance, duct and plenum nozzles, control mechanism, wet chemical cylinder detection and all accessories factory-installed in the hood utility cabinet.
- II. Retailer's fire suppression system shall include a remote pull station located in the path of exit or egress and an automatic gas shut off valve.
- III. Retailer shall provide type K and type ABC fire extinguishers in accordance with all applicable codes and regulations.

C. Exhaust Fan

- I. Retailer shall provide a UL listed utility set exhaust fan with centrifugal blower, fully enclosed motor, adjustable drive pulley, forty-five degree (45°) down discharge, clean-out door, drain plug, insulated penetration curb, vibration isolators and weatherproof service disconnect switch.

D. Other Information

- I. Retailer's exhaust hood shall be installed in compliance with any and all governing authorities.
- II. The installation of Retailer's exhaust hood shall be by a HVAC contractor or a certified company experienced in the installation of commercial kitchen ventilation.
- III. Wall-mounted hoods shall be set on a non-combustible wall constructed of studs and cement board.
- IV. Retailer may submit an alternate package to that directed above which must include complete engineering and schematics of the system, cut sheets of each item in question and justification, in writing, from Retailer's mechanical engineer.
- V. Landlord's shall review Retailer's alternate package and make recommendations to Landlord who, in its sole judgment, shall conditionally accept or reject any alternate package presented.

3. Plumbing

- A. All food court Retailers and other high water users shall have a meter to be furnished and installed by Retailer at Retailer's expense.
- B. In food service premises, grease traps and garbage disposals shall be installed by Retailer at sinks making sure such installation meets the code requirements of the LOCAL JURISDICTIONAL AUTHORITY.

- C. Food court Retailers will share the facilities available in the public toilet rooms but must provide a mop sink for their own spaces.
- D. Food court Retailer's mop sink may be a deep bowl, wall-mounted fixture doubling as a hand washing sink.

Counter-Type Operations

Food court Retailers which require counter-type operations must comply with the following standards:

1. Retailer shall extend the Property flooring material from Retailer's lease line to the counter with the tile must be flush with the Property finish floor.
2. Retailer's counter face must have tile base to match the base on the adjacent neutral piers.
3. The face of Retailer's counter must be glazed ceramic tile, hardwood, solid color plastic laminate, glass block or other materials approved by Landlord.
4. Retailer's countertop must be stainless steel, solid color plastic laminate, other materials approved by Landlord.
5. Variable height glass display cases, if desired, shall be installed one-foot four-inch (1'-4") above Retailer's finished floor.
6. The rear areas of Retailer's space used for storage and/or food preparation shall be screened from public view.
7. Doors to Retailer's rear storage and/or food preparation area must be perpendicular to Retailer's storefront lease line.
8. Customer seating will not be permitted within Retailer's leased premises.

Food Court Sign Criteria

1. Sign band areas are property specific. Retailer's sign vendor shall survey the space prior to production of shop drawings
2. The use of illuminated and neon signs within the food court will be permitted pending Landlord's review and written approval of Retailer's design and construction drawings.
3. All electrical connections, attachment devices, etc. must be concealed.
4. Retailer's sign copy shall be limited to the store name only or an otherwise approved sign design.
5. Graphic representation of Retailer's product will be permitted behind Retailer's counter line.
6. Menu boards, price lists and other signage or graphics within Retailer's space must be at least five feet (5'-0") behind Retailer's lease line.
7. All signage within Retailer's space must be surface-mounted to the walls or soffits.
8. Suspended signs are not permitted unless otherwise approved.
9. Menu boards supplied or produced by a product supplier (i.e. Coke, 7-Up, Pepsi, etc.) are not permitted.
10. Menu boards must be original in design.

Section Six

Mechanical/Electrical Design Criteria

The following are guidelines for Retailer's Mechanical/Electrical systems.

HVAC:

Retailer shall provide all portions of its HVAC system as outlined in, but not limited to, the information provided below:

1. Cooling

- A. Retailer shall furnish and install all HVAC equipment, including curbs, structural support, and roofing repairs, at their cost and expense, and as outlined in the Exhibit B of the lease.
- B. Retailer's HVAC will be designed as per Retailer's needs by its HVAC engineer.
- C. Retailer shall be responsible for cooling load calculations to determine actual cooling requirements.
- D. Any deviation to Retailer's equipment locations, curbing sizes and equipment size shall be at Retailer's expense.
- E. Retailer shall provide cooling during business hours to maintain temperatures outlined in the Lease.
- F. Retailer's rooftop units, if applicable are to have splash blocks placed where required on treads by Landlord's roofing contractor at Retailer's expense.
- G. Retailer may have burglar bars installed in supply air and return air ducts at Retailer's rooftop unit.
- H. Negative air pressure is not permitted.

2. Heating

- A. Retailer shall be responsible for all electrical work including control wiring for heating of its leased premises, or as outlined in the Exhibit B of the lease.
- B. Retailer shall be responsible for calculating its heating load to determine its actual heating requirements.
- C. Any deviations to Retailer's equipment locations, curbing sizes and equipment size shall be at Retailer's expense.
- D. Retailer shall provide heating during business hours to maintain temperatures outlined in the specifications and a minimum of fifty-five degrees (55°) during times other than business hours.
- E. Retailer shall furnish and install a separate electric unit heater for Retailer's storage or service areas if required.
- F. Retailer shall coordinate with Landlord's Retailer Coordinator for the location of Retailer's separate electric unit heater.

3. Air Distribution

- A. Ductwork must be extended by Retailer from Retailer's HVAC equipment with all necessary branch ducts, volume dampers, supply and return air distribution equipment, grilles, registers, etc. as required by Retailer's needs and/or the applicable code(s).
- B. Supply and return air ductwork drops into Retailer's ceiling space from Retailer's rooftop units must be sheet metal or fiberglass, if applicable.
- C. Return air must be ducted due to the Property smoke evacuation system, if applicable.
- D. All systems require duct smoke detectors as required by local governing jurisdiction.

- E. Flexible ductwork is allowed although it must meet all requirements and applicable codes and as verified or directed by Landlord's Onsite Retailer Coordinator.
 - F. Duct heaters are not allowed.
4. Exhaust and Flue
- A. Retailer shall provide and install all exhaust equipment, ductwork, controls, etc. required for the complete installation of each toilet room, exhaust fan as required by the specifications or as directed by Landlord's Onsite Retailer Coordinator and to all applicable codes.
 - B. Any and/or all other necessary Retailer roof penetrations are to be made, flashed and sealed by Landlord's roofing contractor at Retailer's expense.
 - C. Retailer shall provide and install a round, pre-fabricated, double-wall duct breeching for water heaters or other equipment requiring such according to the HVAC specifications and all applicable code requirements.
 - D. All roof-mounted equipment shall be set on pre-fabricated curbs of a type approved by Landlord's Retailer Coordinator.
5. Controls
- A. Retailer shall install unit manufacturer's electric control package as required by the manufacturer's specifications.
 - B. Retailer shall provide a ceiling-mounted indicator light adjacent to Retailer's storefront enclosure to indicate when Retailer's rooftop HVAC unit is in operation.
 - C. Retailer's ceiling-mounted HVAC indicator light must be visible from the Property side of Retailer's space.
6. HVAC Miscellaneous
- A. All show or display window areas are to be adequately ventilated. 2.) Retailer shall wire all items of its HVAC equipment.
 - B. Retailer's HVAC drawings and specifications must be approved by all required authorities having jurisdiction; prior to installation.
 - C. Retailer's HVAC work shall be inspected throughout the construction process for compliance with Retailer's HVAC specifications and code requirements.
 - D. Changes and alternates to Retailer's drawings, specifications and basic building design shall be done at Retailer's expense when approved by Landlord.
 - E. Air balancing of Retailer's HVAC distribution systems and any exhaust or make-up air systems is Retailer's responsibility. Retailer shall provide Landlord with two (2) copies of a certified air balance report prepared by a certified independent balancing contractor. **The certified air balance report must be approved before Retailer will be permitted to open for business.**
 - F. Retailer shall contract with certified HVAC contractor for a "Preventative Maintenance Contract" for quarterly inspections, cleaning and service. **Copy of contract must be provided to property management before Retailer will be permitted to open for business.**
 - G. Retailer's HVAC and other rooftop units are to be labeled prominently by Retailer's contractor with the following information:
 - i. Retailer's space number;
 - ii. Retailer's store name; and
 - iii. The date Retailer's rooftop unit was installed

Fire Extinguishers

Retailer shall furnish and install fire extinguishers of the type, capacity and rating as required by applicable codes and ordinances of governing agencies.

Plumbing and Gas Piping

1. Landlord shall **"Only"** install a valved and capped cold-water line and a waste line to Retailers premises or as outlined in the Landlord work section of Exhibit B of the Lease.
2. Exhaust and sanitary vents may not be located within ten feet (10'-0") of any supply or air intake. The location of exhaust and sanitary vents are subject to Landlord's approval.
3. All piping materials shall be in accordance with Landlord's specifications. Water lines shall be "no joint" or brazed joint of "Type K" when placed underground and Type L copper pipe with soldered connections when placed above ground. Sanitary lines shall be "Hub" type when below ground and "No Hub" type when above ground. PVC pipe shall be permitted only if allowed by code. Gas lines shall be screw or welded and painted with two (2) coats of rust inhibitive paint where exterior to the building, including the roof. All hot and cold-water lines shall be insulated. No ABS or CPVC piping materials are allowed.
4. All water heaters shall be set in metal drain pans and have a pressure temperature relief valve draining into the floor drain. When a water heater is located above the ceiling, access shall be by a ladder, ceiling hatch, platform and light. Retailer must submit engineered structural design drawing of proposed support system.
5. Condensate lines for refrigeration must terminate within Retailer's premises in accordance with the requirements of jurisdictional authorities and Landlord's insurance carrier.

MEP Penetrations/Roofing/Structure

1. Landlord reserves the right to refuse to permit the installation of any openings which exceed the capacity of the structural system or which, in Landlord's opinion, would have any appearance detrimental to Landlord's building.
2. Retailer shall provide engineered and sealed structural drawings including calculations which provide sufficient evidence to Landlord that existing structure can support Retailers proposed new equipment. If additional modifications are required to be performed, Retailer to be responsible to perform the work at Retailer's expense; however, Landlord reserves the right to perform the work at Retailer's expense.
3. Landlord reserves the right to refuse the installation of any roof or wall- mounted equipment or to require screening if, in Landlord's opinion, the appearance of such equipment would be detrimental to the appearance of Landlord's building or exceeds the capability of Landlord's structural system.
4. Retailer shall use Landlord's designated roofing contractor to set and flash all roof-mounted equipment on pre-manufactured curbs such as PATE or equal.

Electric

1. Electric Service:

- A. If specifically noted as Landlord work, or existing in the premises, Landlord shall furnish an empty conduit to accept Retailer provided conductors.
- B. Retailer's combining two or more spaces shall be required to combine electrical services to one service
- C. If Retailer is performing work connecting to, modifying, and/or replacing existing Landlord distribution gear all work must be coordinated with, and approved by, Property management.
- D. The Landlord-furnished conduit originates from a meter distribution panel furnished by Landlord and located in an electrical room.
- E. Retailer's electrical load shall be based upon Retailer's design requirements.
- F. Retailer shall arrange with the local power company for meter installation.

2. Telephone Service

- A. Retailer shall contact the local telephone company to make arrangements for and payments associated with telephone service.
- B. Retailer shall be responsible for all conduits as required by the local telephone company and for supplying the services necessary for telephone wires in Retailer's leased premises.

3. Electrical Construction

- A. All electrical materials shall be new and bear the UNDERWRITERSLABORATORIES label.
- B. All work shall be performed in full compliance with the latest national electrical code and all state and local codes and/or ordinances having jurisdiction.
- C. All breakers shall be bolted type. Twenty percent (20%) additional spare breaker capacity shall be provided.
- D. The lighting for Retailer's show windows shall be time-switched for control of show window lighting.
- E. Branch circuit wiring shall be run in EMT or may be armored cable (BX) when approved by local inspectors. **EMT is not permitted in the earth or concrete.**
- F. All conductors shall be copper.
- G. Outlet boxes and covers therefore shall be galvanized or sherardized one-piece knockout type. Retailer shall consult with Landlord regarding the type of box required for outlet boxes in damp or exposed locations. Lighting fixture outlets shall be provided with 1/8" fixture studs and plaster rings. Outlet boxes for wiring devices, *i.e.* switches, receptacles, *etc.* shall be a minimum of four inches (4") square fitted with a device cover to suit. Outlet boxes shall be fastened by means of screws or shall be supported by means of approved hangers.
- H. All telephones with services thereto shall be provided by Retailer. All telephone charges shall be paid by Retailer directly to the telephone utility company furnishing telephone service. All facilities to serve the leased premises required by the telephone company to provide service shall be furnished by Retailer.
- I. Lighting fixtures shall bear the UL label and be of a type approved by all applicable inspection authorities. Recessed fixtures installed in furred spaces shall be connected by means of flexible conduit and "AF" wire to run to a branch circuit outlet box which is independent of the lighting fixture.
- J. Distribution panels, lighting panels, motor starters and push button stations shall be identified with engraved BAKELITE nameplates.

- K. Retailer's hot water heater shall be electric automatic with less than a one hundred (100) gallon capacity. Special metering for Retailer's water heater shall be provided by Retailer, if required.
- L. Retailer shall provide a light and convenience outlet near all mechanical equipment above the fixed suspended ceiling. The switch to the light shall be located near an access panel to the ceiling space and shall have a continuous lighted pilot for ease of location.
- M. Exit and emergency lighting shall be provided by Retailer in accordance with the NATIONAL ELECTRICAL CODE AND ALL APPLICABLE life safety code requirements.

Fire Sprinkler System

1. Where required by applicable codes, Landlord has designed an automatic fire sprinkler system through the Property building in compliance with the requirements of local and state governmental agencies.
2. Any modifications to Landlord's standard grid system must be submitted to Landlord by Retailer prior to performing work.
3. Additional heads or relocation of the same required by Retailer's plans or the use of its premises shall be done by Retailer using Landlord's designated sprinkler contractor:
4. If some portion of Retailer's sprinkler system has been installed prior to the construction of Retailer's leased premises, the cost for modifying the sprinkler system because of Retailer's design including, but not limited to, the cost of relocating, resizing or adding sprinkler mains or heads shall be at Retailer's expense.
5. Landlord reserves the right to refuse to permit the installation of a sprinkler system exceeding the supplying capacity of Landlord's bulk mains.

Smoke Evacuation System

1. This property may be equipped with a smoke evacuation system. Retailer is responsible to connect to existing system, if applicable.
2. Contact property management team to coordinate requirements.

Section Seven

Sign Criteria

Prior to signage design contact the specific property for any specific signage requirements set forth by the property or local jurisdiction.

General

1. Storefront signage provides one of the first impressions a patron has of Retailer's store and can attract, entertain and convey an image at a distance like no other component of a Retailer's store.
2. The goal of the Retailer's signage is to achieve the foregoing objectives and, at the same time, honor and reflect the Property's image of upscale comfort and excitement and to creatively apply novel materials, concepts and combinations to take Retailer's signage beyond the common and mundane.
3. Retailer must identify its space by producing signage for its storefront, at Retailer's expense which is appropriate, creative and complimentary to the architecture of its respective storefront.
4. The wording of the insignia is limited to the Retailer's trade name (DBA), logo, hallmark, insignia or trade identification only, listed in Retailer's Lease agreement. Each party's customary signature or logo, hallmark, insignia, or other trade identification will be respected and consideration given during Landlord's review and approval process.
5. Tag lines (regardless of DBA) and signs advertising products, services, vendors or containing marketing phrases are strictly prohibited.
6. Trademark logos (circle R) are strictly prohibited
7. Retailer shall not install any roof top signs
8. All sign types, back-lit, inner-lit, channel-lit, hoop lights, trough lights, conduct light or edge-lit, are reasonable options.
9. Brass, steel, gold leaf, wood, glass, and neon are all acceptable signage materials when used appropriately and in combination with the surrounding storefront field treatments.
10. Signage shall be affixed to the sign band area or suspended between the sign band and/or bulkhead with the front facing the Property or concourse, and cannot be attached to Landlord's bulkhead and/or demising walls.
11. Fabrication and installation of Retailer's signage is strictly Retailer's responsibility once approved by Landlord.
12. Shop drawings of Retailer's signage must be submitted to Landlord showing the sign as it would be seen on Retailer's storefront, the technical documentation of the sign in proper scale, a section of the sign showing all mechanicals and the specifications as well as color samples in the sign and field colors for Landlord approval. See provided examples
13. Sign Area:
 - A. Retailer's sign area cannot exceed a length greater than 70% of the area of Retailer's storefront on the Property or thirty feet (30'), whichever is larger.
 - B. Retailer's sign area shall be located at least 18" from each lease line. Landlord reserves the right but is not required to vary these requirements on an individual or overall basis
 - C. Retailer's sign area shall be measured by circumscribing a rectangle around the body of the sign.
14. Retailer's sign shall not exceed an area greater than (120 SF) of Retailer's storefront sign area.

15. Letter heights

Retailers signs shall be sized based on the following:

 - A. If the storefront width is twenty feet (20') or less the maximum letter height of the letters shall be 24".
 - B. If the storefront width is greater than twenty feet (20'), the maximum height of the letters shall be 30"
 - C. For Retailers greater than 5,000 square feet, the maximum height of the letters shall be 36"
 - D. For Retailers greater than 15,000 square feet, the maximum height of the letters shall be 48"
 - E. For Retailers greater than 24,000 square feet, the maximum height of the letters shall be 60"
16. Major Stores
 - A. Major Retailers may have their usual identification signs on the building.
 - B. Major Retailer shall not have rooftop signs
 - C. Major Retailer signage shall not be flashing, moving, or audible
 - D. Major Retailer shall follow the local zoning ordinance.
17. Retailer's signage shall face the Property/concourse area only.
18. Landlord shall permit larger illuminated signs for restaurant Retailers subject to the approval of Landlord and the local governing jurisdiction.
19. A Secondary Sign, in addition to the Primary Storefront Sign, may be permitted pending storefront elevations and space location
20. Rear signage, if approved by Landlord, shall be limited to 70% of the allowable front fascia signage area
21. Retailers shall install one (1) identification sign on its rear service door which is three (3") high and consists of Helvetica Medium type style, all capital letters indicating the store name as on the Retailers storefront sign band.
22. Retailers requesting pylon signage must get approval from the WPG Property Leasing Representative. If permitted, all pylon signage will be limited to the design of the property's pylon. Pylon signage shall be submitted for Landlord review and approval.
23. Blade signs: Not all properties permit use of blade signage. Retailer to contact local property management for specifics
 - A. A blade sign shall be no thicker than 9" at its greatest dimension.
 - B. A blade sign shall project horizontally no more than 3'6" from the face of the projected storefront line.
 - C. The blade sign shall extend vertically no closer than 8'0" and no more than 11'0" from the Property floor.
24. Retailers signs shall conform to all applicable governmental regulations, laws, zoning requirements and title restrictions.
25. Sign permits, if applicable, shall be obtained by the Retailer and are required for all related work prior to commencing with field installation
26. All signs shall be constructed without exposed fasteners or attachments.
27. All signs shall be constructed of high-quality materials (i.e. wood, glass, plexiglass, metal, etc.)
28. All signs shall be adequately and comfortably illuminated.
29. Light leaks shall not be permitted and shall be immediately repaired by Retailer.
30. Neon sign brightness shall be subject to Landlord's approval. Maximum 100 FT Lamberts
31. All letters shall be approved by Underwriter Laboratories and carry their seal of approval. The color of the letters, shall be selected by the Retailer, and approved by Landlords at its sole discretion. Please note some properties have specific approved colors.
32. High gloss finishes on the sign face, trim cap and returns are not permitted - use semi-gloss or flat finishes. It is the Retailers responsibility to verify the finish conditions prior to fabrication
33. Sign illumination must be connected to a 7 day / 24-hour time clock to be set to the hours specified by the property

34. The following types of signs are suggested as allowing the greatest amount of individual design freedom and have been found to be the most successful when used in a Property situation:
- Individual channel letters with acrylic faces internally illuminated;
 - Reverse channel letter with halo illumination, opaque letter-sides and faces and non-reflective background
 - Incised signing cast into or carved out of an opaque material, illuminated externally; (Approved on Case by Case Basis)
 - Edge-lit, sandblasted glass
 - Pinned letters using an exposed light source
 - Halo-lit letters on an opaque background
 - Push through letters - If used must penetrate at minimum of 3/8"
35. Prohibited Signage
- Non-illuminated signs
 - Box or Cabinet style
 - Paper, cardboard, Styrofoam, stickers, or decals hung around, on or behind Retailer's storefront
 - Painted, non-illuminated letters
 - Signage identifying leased departments or concessionaires contained within Retailer's leased promises
 - Neon set in front of a clear reflective surface unless specifically approved by Landlord.
 - Flashing, flickering or moving lights, blinking lights, animation, and emission of sounds or scents
 - Exposed raceways, ballast boxes and transformers
 - Exposed manufacturer's name, stamp, or decal
 - Luminous, vacuum-formed type plastic letters, and
 - Unedged on uncapped plastic letters or letters with no returns and exposed fastenings.
 - Noise making signs
 - Illuminated signage, posters, banners, or graphics against glass interior

Construction Requirements

1. All letters shall be fabricated using full-weltd construction
2. The location of all openings for conduit sleeves and supports in the sign panel of the building walls shall be indicated on Retailer's signage drawings
3. Retailer's sign contractor shall repair any damage to any work caused by Retailer's sign contractor's work.
4. Retailer shall be responsible for the operations of Retailer's sign contractor.
5. All electrical signs shall bear the UL label
6. All electrical signs shall comply with all building and electrical codes regarding fabrication and installation.
7. Exposed conduit, tubing, crossovers and wiring raceways shall not be permitted.
8. All conductors, transformers, cabinets and other equipment shall be concealed.
9. All signs, bolts, fastenings and clips shall be of hot dipped galvanized iron, stainless steel, aluminum, brass, bronze or black iron materials.
10. Retailer's sign manufacturer's label or other identification shall not be permitted on the exposed surfaces of Retailer's signage except those required by local ordinance which shall be inconspicuous.
11. Threaded rods or anchor bolts shall be used to mount Retailer's sign letters which shall be spaced out from the background panel.

12. Angle clips attached to letter sides shall not be permitted.
13. Retainers used as the perimeter of sign letter faces shall match in color and finish to the sides of the letters.
14. Simplicity and restraint in material selection is important; however, the material selection, its method of application and its detail construction should be consistent with the execution of Retailer's total storefront.
15. As the administrator of the store design criteria, Landlord is the final arbitrator of design issues.
 - A. Any material, configuration, sign or other aspect of Retailer's store design which, in Landlord's sole opinion, is detrimental will be rejected.
 - B. Landlord reserves the right to provide the final design, at Retailer's expense, regardless of the type of storefront if an acceptable design cannot be found otherwise.
16. Special circumstances may require interpretation of these criteria and Landlord shall remain as along as the spirit of the criteria are not undermined.

Major Retailer Signage

1. Exterior Walls of Major Retailer Store Buildings
 - A. Major Retailer work is required to install signs on the exterior of its building using the type of signs Retailer typically uses on its building constructed in Properties containing at least 1,000,000 SF of gross floor area.
 - B. Major Retailer's signage shall only identify it by its trade name or alternate trade name used by Retailer as permitted by Retailer's Lease Agreement.
 - C. No other names or trade names shall be affixed to the exterior of Major Retailer's building.
 - D. Major Retailer's signs shall be illuminated but shall not contain flashing, flickering, or moving lights, blinking lights, animation or emission of sounds or scents.

Landlord's signage

1. Exterior of Landlord's buildings
 - A. Landlord shall be permitted to install signs on the exterior of Landlord's buildings using the type of signs typically found in shopping centers, containing at least 1,000,000 SF of gross floor area.
 - B. Landlord shall be permitted to install signs otherwise in the common area outside the enclosed Property for purposes of providing directional, informational and other types and kinds of signage which are typically found in shopping centers containing at least 1,000,000 SF of gross floor area.
 - C. Landlord's signage may be illuminated but shall not contain flashing, flickering or moving lights, blinking lights, animation or the emission of sounds or scents.
2. Inside the Enclosed Property
 - A. Landlord shall be permitted to install signs in the interior of the enclosed Property using the types of signs typically found in shopping centers containing at least 1,000,000 SF of gross floor area.
 - B. Landlord's signage shall not contain flashing, flickering or moving lights, blinking lights, animation or the emission of sounds or scents.

Minimum Submissions

1. Retailer is required to submit fabrication drawings to Landlord for approval prior to fabrication and installation.
2. Retailer shall submit the following:
 - A. ½"-1' elevation of sign
 - B. ¼"-1' storefront or exterior elevation with signage
 - C. 1"-1' sections showing installation, power, and transformer location
 - D. 1"-1' section through sign letters
 - E. Color rendering, elevation or photograph of a like sign
 - F. Material and color samples
 - G. Classification, name/logo and merchandise listing for merchandise
 - H. Identification panel; and
 - I. The sign manufacturer's shop drawings showing construction and installation, including mounting devices. See provided example

Sign Installation

1. Signage shall not be installed without installation drawings bearing Landlord's approval. This will be checked onsite.
2. Retailer shall not install unapproved signage under any circumstances
3. Retailer's sign shall be installed by a state and/or local certified and/or licensed sign contractor as approved by Landlord and in accordance with local, state and national codes, if applicable.
4. Retailer's sign installer shall protect all flooring surfaces and bulkhead finishes during installation and/or servicing of Retailer's signage
5. Sign installation shall be coordinated with Landlord's onsite representative.
6. All electrical connections shall be by a locally-licensed electrician.
7. Interior signage must be installed before or after Property operating hours.

Section Eight

Close-out Requirements

RETAILER CLOSE-OUT REQUIREMENTS

Prior to releasing the Retailer Construction Allowance or Retailer's contractor's Construction Damage and Security Deposit, the following close-out requirements must be completed and delivered to Landlord in addition to any additional information as may be required in the Lease:

1. a detailed breakdown of Retailer's final and total improvement costs, together with receipted final invoices showing payment;
2. one (1) complete electronic set of as-built construction documents;
3. a copy of the required service and/or maintenance contracts;
4. Contractor's Affidavits together with valid Waivers of Lien, indicating payment in full for labor, materials and subcontractors and one (1) year warranties for materials and workmanship commencing the date Retailer opens its store for business;
5. a copy of Retailer's Certificate of Occupancy; and
6. a copy of the completed Landlord's Onsite Retailer Coordinator's punch list.

212301



SOUTHERN PARK MALL
SPACE#: | STORE#:



BARRICADE GRAPHIC SAMPLE

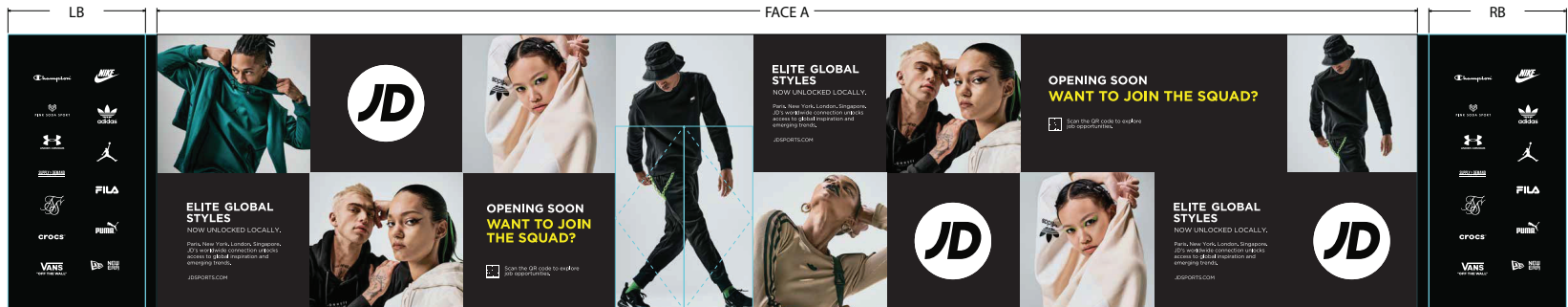

PHONE: 866-866-0925
WEB: www.bostonrs.com

DATE: 03/17/22

DRAWING: BGA #01

- DIMENSIONS:
- Preliminary From Drawings (NO site survey)
 - Pre-Construction DIMS (from Site Survey)
 - Post-Construction DIMS

SCALE: 1" = 1' 0"

- SURFACE TYPE:
- Modular: BRS
 - Plankwallz
 - Plywood
 - Drywall
 - Glass

BRS REP: AC

DESIGNER(s): SRH

DISCLAIMER: Barricade plans are subject to change. Boston Retail Solutions recommends a site survey always be performed to confirm "as built" dimensions for graphics to be created and installed accurately. Boston Retail Solutions does not warranty or assume any liability for 3rd party printing/installation.

TEMP STOREFRONT GRAPHIC SAMPLE

E04 **TEMPORARY WINDOW VINYL** **PB-WV-TMP-1 & PB-WV-TMP-3**

Scale: 3"=1'-0"



HOURS, PHONE NUMBER & SOCIAL MEDIA COPY TO BE PROVIDED

APPLICATION: Surface applied digitally printed temporary vinyl graphics to outside of glass
FONT: Raleway SemiBold
QUANTITY: (8) TEMPORARY WINDOW GRAPHICS REQUIRED

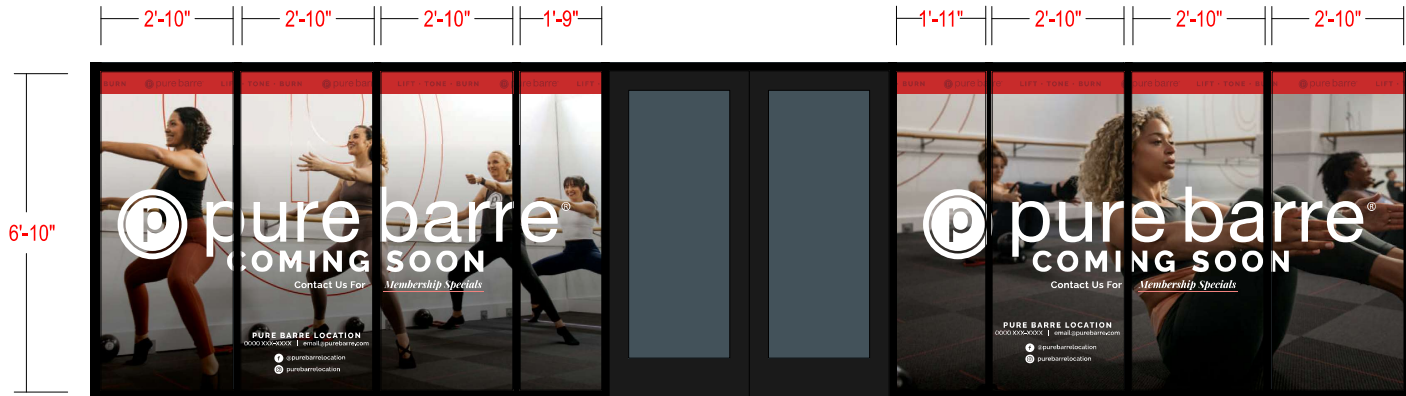

PB-WV-TMP-1

PB-WV-TMP-3



Scale: 3/8"=1'-0"

COLOR PALETTE

-  3M 7725-20 Matte White
-  3M 3630-33 Red
-  3M IJ-3555 Temporary Vinyl

All paint finishes to be Satin unless otherwise specified

StratusTM

stratusunlimited.com

8959 Tyler Boulevard
Mentor, Ohio 44060
888.503.1569

CLIENT:

ADDRESS:
 1015 W UNIVERSITY AVE
 SUITE 507
 GEORGETOWN, TX 78628-5353

ORDER NUMBER:
1187431
SITE NUMBER:
6000004
ELECTRONIC FILE NAME:
 G:\ACCOUNTS\X\EXPONENTIAL FITNESS_LOCATIONS\2022\TX\Pure_Barre_Georgetown\Pure_Barre_Georgetown.cdr

PROJECT NUMBER:
85705
PROJECT MANAGER:
HECTOR MARTINEZ

PAGE NO.:
6

Rev #	Req #	Date/Artist	Description	Rev #	Req #	Date/Artist	Description
Original	411585	12/20/22 BB					

PRINTS ARE THE EXCLUSIVE PROPERTY OF STRATUS. THIS MATERIAL SHALL NOT BE USED, DUPLICATED, OR OTHERWISE REPRODUCED WITHOUT THE PRIOR WRITTEN CONSENT OF STRATUS.

INTERIOR SIGNAGE SAMPLE



Sales: Chris Franks
Project Manager: Michelle Johnston

1500 Polaris Parkway #2192
Columbus, OH 43240

Table of Contents

Page 1 - Cover Page

Page 2 - Front Elevation

Page 3 - 30" Face and Reverse Lit Exterior Channel Letters

Revision Notes

Rev 1:



SIGN COMPANY LLC.

731-926-4448 • 800-953-3744 • Fax 731-926-2022
www.designteam.net

INTERIOR SIGNAGE SAMPLE

Front Elevation

A 30" Direct Mount Channel Letters

A

19'-11 1/8" LEASE LINE
(VERIFY IN FIELD)

Rev 1
Rev 2
Rev 3
Rev 4
Rev 5
Rev 6



Designer: JH	Date: 03/10/22	Option # 1 - JH
Client: Jamba Juice - 1500 Polaris Parkway #2192 Columbus, OH		
File Path: Z:\Restaurant\JAMBA JUICE\OH\Columbus\1500 Polaris Parkway Space #2192\New Location 3-9-2022		

Proof Is Approved. Proceed With Production Of Order

Proof Is Approved With Corrections. Make Corrections As Indicated And Proceed With Production Of Order

Signature: _____

I have reviewed this proof in regard to: Sign type, order quantity, and accuracy of icons, symbols, and text (e.g. spelling capitalization, punctuation).

Print Name: _____

Date: _____



These plans are the exclusive property of Design Team Sign Company and are the result of the original work of its employees. They are submitted to your company for the sole purpose of your consideration of whether to purchase these plans or to purchase from Design Team Sign Company a product manufactured according to these plans. Distribution or exhibition of the plans to anyone other than employees of your company, or use of these plans to construct a product similar to one embodied herein, is expressly forbidden. In the event that exhibition or construction occurs, Design Team Sign Company expects to be reimbursed \$500 in compensation for time and effort entailed in creating these plans.

INTERIOR SIGNAGE SAMPLE

Face Lit/Reverse Lit Channel Letters w/Push Thru Cabinet

JJA-V1-CLFRL30-SJB

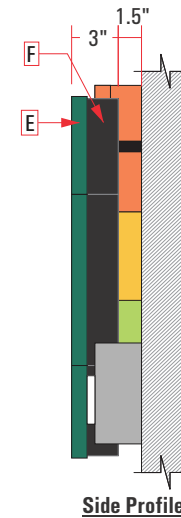
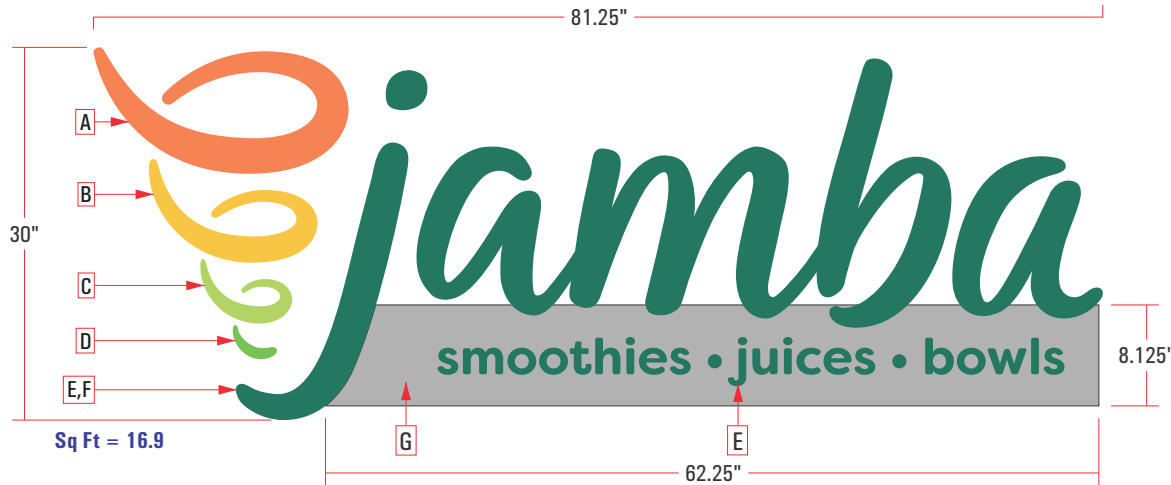

SWIRL: Materials

1	.040 Alum. Returns / Inside Painted White
2	1" Jewelite Trimcap - Painted to Match Faces
3	.177" 7328 White Acrylic Face
4	.063 Aluminum Back - Pre-Painted White
5	.5" Flex Conduit
6	White LED Modules
7	Mounting Hardware
8	.25" Weep Hole
9	Power Supply
10	Disconnect Switch
11	Primary Electrical Leads (Power by Others)

JAMBA: Materials

12	.040 Alum. Returns / Inside Painted White
13	1" Trimcap - Painted to Match Faces
14	.177" 7328 White Acrylic Face
15	White LED Modules
16	.177" Clear Poly. w/2nd Surf. 3635-70 Diff.
17	.5" Flex Conduit
18	.25" Weep Holes
19	1.5" PVC Spacers
20	3/8" All-Thread w/1-5/8" x 1-5/8" Uni-Strut
21	Power Supply
22	Disconnect Switch
23	Primary Electrical Leads (Power by Others)

Colors & Finishes

A	3M 3730-44L Orange / Paint PMS 1575C
B	3M 3730-125L Golden Yellow / Paint PMS 1235C
C	3M 3730-106L Brilliant Green / Paint PMS 360C
D	3M 3730-156L Vivid Green / Paint PMS 348C
E	3M 3730-76L Holly Green / Paint PMS 555C
F	Prefinished Black Returns w/White Inside
G	Paint Dunn Edwards Gray Wolf DE6354

Notes

- Swirl Logo is Direct Mount and Face Lit Only

SJB: Push Thru Cabinet Materials

24	.040 Alum. Returns / Inside Painted White
25	.125" Routed Aluminum Face
26	.090 Aluminum Back - Pre-Painted White
27	.5" Clear Push Thru Acrylic
28	White LED Modules
29	Power Supply
30	.5" Flex Conduit
31	1" x 1" Alum. Tube Bracing
32	.25" Weep Hole
33	3/8" All-Thread w/1-5/8" x 1-5/8" Uni-Strut
34	J-Box & Primary Electrical (Power by Others)

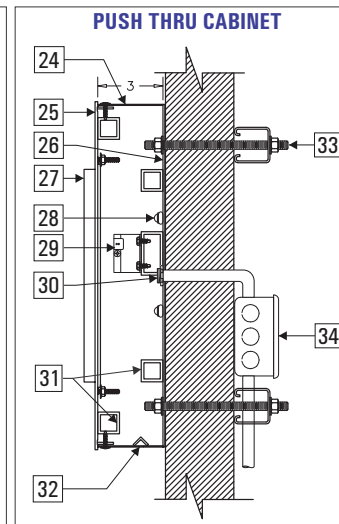
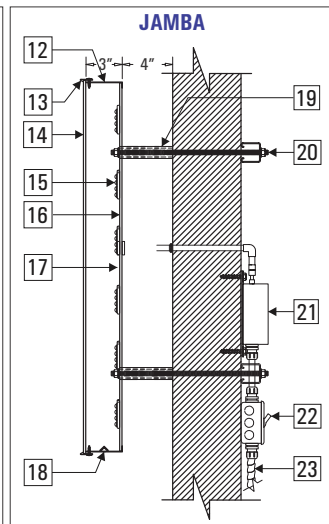
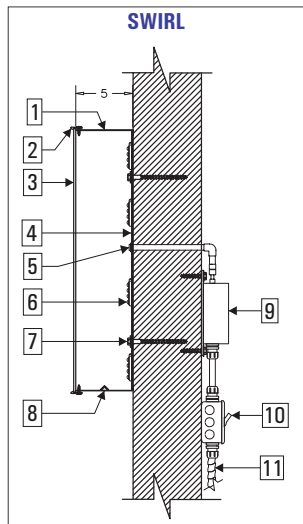

Designer: MEB Date: 3-10-19

Client: Jamba Juice

File Path: z/Restaurants/JJ/CorpSpecs

- Proof Is Approved. Proceed With Production Of Order
- Proof Is Approved With Corrections. Make Corrections As Indicated And Proceed With Production Of Order

Signature: _____

I have reviewed this proof in regard to: Sign type, order quantity, and accuracy of icons, symbols, and text (e.g. spelling capitalization, punctuation).

Print Name: _____

Date: _____



These plans are the exclusive property of Design Team Sign Company and are the result of the original work of its employees. They are submitted to your company for the sole purpose of your consideration of whether to purchase these plans or to purchase from Design Team Sign Company a product manufactured according to these plans. Distribution or exhibition of the plans to anyone other than employees of your company, or use of these plans to construct a product similar to one embodied herein, is expressly forbidden. In the event that exhibition or construction occurs, Design Team Sign Company expects to be reimbursed \$500 in compensation for time and effort entailed in creating these plans.

EXTERIOR SIGNAGE SAMPLE

A MAIN ID - EXTERIOR
FRONT LIT CHANNEL LETTERS - WIREWAY MOUNTED



CHANNEL LETTERS

- Qty One(1) set
- 30" x 152"
- 5" Deep Front Lit Channel Letters
- 3/16" White/Blue Acrylic Faces #7328
- 1" Black Trimcap
- Wrisco Black Returns
- Principal Quick MOD 2 White LED's
- Wireway Mounted

VINYL

DAY/NIGHT- LAB- NOW - STRIPE

Client Name: **ANY LABS NOW**
Address: 1013 W. University Ave, Suite 182 Georgetown, TX 78628
Start Date: 10.4.22
Filename: ANY LABS NOW _10-4-22.ai
Page: 1 of 1
Project Manager: Dwayne Kurecka
Contact: dwayne@texascustomsigns.com

Signs will be manufactured with 120 Volts A/C. All Primary electrical service to the sign is the responsibility of the buyer. This sign is intended to be installed in accordance with the requirements of Article 600 of the National Electrical Code and/or other applicable local codes. All bonding & grounding must be done by a qualified, licensed electrician and in accordance with UL Article 600 of the NEC. The location of the disconnect switch after installation shall comply with Article 600.6(A) (1) of the National Electrical Code.

This is an original un-published drawing created by Texas Custom Signs®, unless otherwise indicated. It is submitted for your personal use in regards to the project being considered. You are not to show these drawings to anyone outside your organization, nor can you use, reproduce, copy, or otherwise exhibit them in any fashion not directly related to the project being planned and produced by TCS.

*If indicated, the above design is preliminary. While every attempt is made to produce the finished product exactly as it appears on this artwork, certain exceptions may be made re: size, color, finish, materials, etc. These modifications are typically made to insure structural integrity, accessibility, installability, serviceability, or other. If desired, please request a finalized shop drawing from your contact before production begins to address any concerns or differences from this drawing.

Client Approval _____ Date _____



512.401.6500 • 512.401.6502
2507 Windy Terrace • Cedar Park • Texas • 78613

COPYRIGHT 2022 TEXAS CUSTOM SIGNS® ALL RIGHTS RESERVED 